

(O) Graphic Panel

GP-2480(240×80dot, touch type) ————— O-1

(A)
Counter

(B)
Timer

(C)
Temp.
controller

(D)
Power
controller

(E)
Panel
meter

(F)
Tacho/
Speed/
Pulse
meter

(G)
Display
unit

(H)
Sensor
controller

(I)
Switching
power
supply

(J)
Proximity
sensor

(K)
Photo
electric
sensor

(L)
Pressure
sensor

(M)
Rotary
encoder

(N)
5-Phase
stepping
motor &
Driver &
Controller

(O)
Graphic
panel

(P)
Production
stoppage
models &
replacement

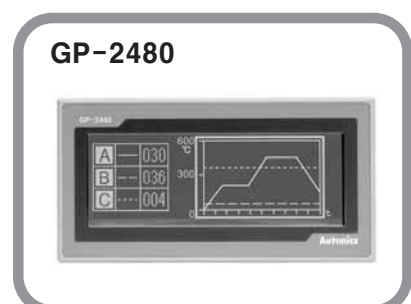

GP-2480 Series

38mm Graphic Panel with Touch Screen, Slim design, and better Reliability

■ GP(Graphic Panel) 2480

GP-2480 is a graphic interface device monitoring multiple control operations of PLC and other control units.

It indicates processing values or operation status of control devices and enables the communication between operators and user so that it replaces HMI(Human-Machine Interface) and MMI(Man-Machine Interface).

It displays control parameters and data on LCD screen, and they are easily set and managed by touching screen.

It offers better data transfer between GP and controller by the serial communication method.

The variables are displayed with tags; for example, the numerical value of temperature is shown with a tag, and the change in temperature for time can be graphed on the screen.

The data on GP-2480 can be edited and downloaded by user's preference using the software, GP Editor.

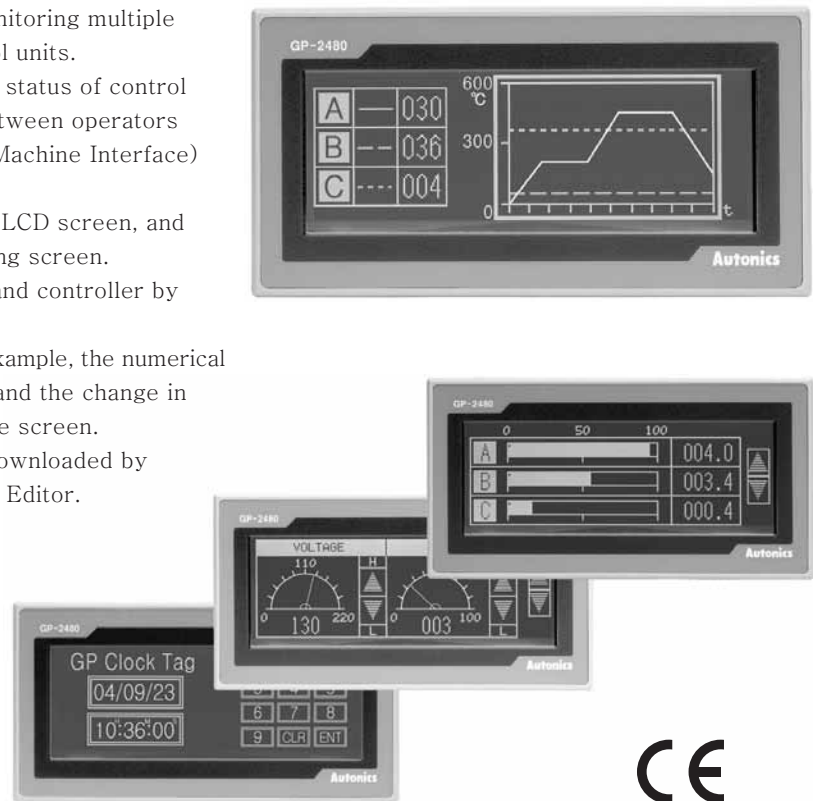

■ Features

- Slim 38mm of space saving device (W145×H74×D38mm)
- High resolution (240×80 dot), display max.400 characters
- 6×6, 8×8, ASC II, high quality view of numbers
- 8×16 ASC II, 16×16 of regional characters
(1, 2, 3, 4, 5, 6, 7, 8 times bigger for width/0.5, 1, 2, 3, 4, 5 times bigger for height)
- Able to save max. 500 pages of user screen
- Communication between heterogeneous controllers
- Able to monitor 2 controllers simultaneously and relay the communication
- Multi monitoring function : Connect same controllers to PLC2 connection port (Software) English, Korean (Additional language support can be available by firmware)
- Support multi font (Various bitmap fonts, user-defined fonts)

Default font		8×16 pixel
Available characters	6×8 pixel	40 characters×10 lines=400 characters
	8×8 pixel	30 characters×10 lines=300 characters
	8×16 pixel	30 characters×5 lines=150 characters
	16×16 pixel	15 characters×5 lines=75 characters
	32×32 pixel	7 characters×2 lines=14 characters
Font size	Width	1~8 times
	Height	0.5, 1~5 times

- Device monitoring function : It is able to monitor the activities of connectable controller devices without designed data.
- Touch interface : It is able to operate GP using touch switch on front screen

Graphic Panel

■ Specifications

Model		GP-2480-SBD0	GP-2480-SBD1	
LCD type		STN Blue Negative		
Resolution		240×80 dots		
Display area		112.8mm×37.6mm		
Color		Single color (Blue, White)		
LCD visible angle		30° of Up/Down/Left/Right direction		
Backlight		White LED		
Battery life cycle		3 years at 25℃		
Brightness		Adjust as software		
Serial communication		Each of RS232C, RS422	2 ports of RS232C	
Applicable device		PLC (Refer to "Communication manual"), Printer, Barcode reader		
Graphic drawing software		GP Editor		
Text font size		<ul style="list-style-type: none"> • 6x8, 8x8 ASCII character, High quality number • 8X16 ASCII character, 16X16 regional character (Width 1,2,...,8 times, Height 0.5,1,2,...,5 times) 		
User Screen	Graphic drawing memory		512KB	
	Figure display		Line, Rectangle, Circle, Text, Bitmap	
	Tags	Numeral display	Display the designated device as numerical value. (Decimal, hexadecimal, octal, binary, real number)	
		ASCII display	Display the designated device value as ASCII character.	
		Time display	Display current time or date.	
		Alarm history	Register alarm history.	
		Alarm list	Display generated (not backed up) alarm.	
		Comment display	Display the designated comment as device status or value.	
		Lamp	Display lamp as device status.	
		Part display	Display the designated parts as device status and value.	
		Line graph	Display several device values with a graph of broken line.	
		Trend graph	Display change of device value for time with a graph of broken line.	
		Bar graph	Display a device value with a bar graph.	
		Statistic graph	Display a ratio of several device values with pie graph.	
		Panel meter	Display a device value as panel meter.	
		Touch key	Screen is switched, word/bit device values are set when it touched.	
	Numeral input	Configure user input value in device.		
	ASCII input	Configure user input ASCII code value in device.		
	System information function		Monitor/control GP operation from PLC.	
	Recipe function		Read/Write several PLC device collectively.	
	Security function		Only acceptable user can observe/operate important data.	
	Barcode read function		Connect barcode reader, read barcode.	
	Floating alarm function		Warning message is floated when alarm is generated.	
	Time operation		Specific bit device is ON/OFF for designated day and time.	
	Overlap window		Available to form dynamically overlapping another base screen on the base one.	
	Observe status function		Change PLC device status/value of PLC when trigger is generated.	
	System Screen	Monitoring		Monitor connected PLC device and change the status.
Preference		Language selection	Designate system language and character set.	
		Channel connection	Configure connection device of serial port connected to CH1, CH2, editor, printer, barcode reader and serial setup.	
		Current time	Configure current date and time.	
		Delete user data	Delete user data.	
		Configuration/access key	Designate the configuration/access key position of system menu.	
		Buzzer	ON/OFF buzzer	
		Switching of user screen	Configure time for initial screen when power it on.	
		Backlight	Configure Backlight OFF time if there is no operation.	
		Battery	Display the percentage of battery remaining.	
		Contrast	Adjust LCD contrast.	
Configuration of function		Data transmission	Display during communication (Download/upload) between GP and editor.	
		Time switch	Configure time switch	
		Print out	Print alarm history with serial printer.	

(A) Counter

(B) Timer

(C) Temp. controller

(D) Power controller

(E) Panel meter

(F) Tacho/Speed/Pulse meter

(G) Display unit

(H) Sensor controller

(I) Switching power supply

(J) Proximity sensor

(K) Photo electric sensor

(L) Pressure sensor

(M) Rotary encoder

(N) 5-Phase stepping motor & Driver & Controller

(O) Graphic panel

(P) Production stoppage models & replacement

GP-2480 Series

Specifications

System Screen	Data check	Basic screen	Display title and number of base screen user made.
		Window screen	Display title and number of window screen user made.
		Comment	Display comment list downloaded in main body.
		Check using memory	Display status of using graphic drawing memory.
		Check model and version	Display model and firmware version of GP.
Ambient temperature		0°C ~ 50°C (at non-freezing status)	
Storage temperature		-20°C ~ 60°C (at non-freezing status)	
Ambient humidity		35% ~ 85% RH (at non-dew status)	
Insulation resistance		Min. 100MΩ (at 500VDC mega)	
Ground		3rd grounding (Max. 100Ω)	
Dielectric strength		500VAC (50/60Hz) for a minute	
Noise strength		The square wave noise (Pulse width 1μs) by the noise simulator with ±1000V R/S phase and repetition frequency 60Hz	
Vibration	Mechanical	0.75mm amplitude at frequency of 10~55Hz (for a minute) in each of X, Y, Z directions for an hour	
	Malfunction	0.5mm amplitude at frequency of 10~55Hz (for a minute) in each of X, Y, Z directions for 10 minutes	
Protection structure		IP65 (IEC standard)	
Accessory		Fixing bracket : 4 pcs, Rubber waterproof ring, Battery (Built-in)	
Unit weight		Approx. 300g	

Dimensions

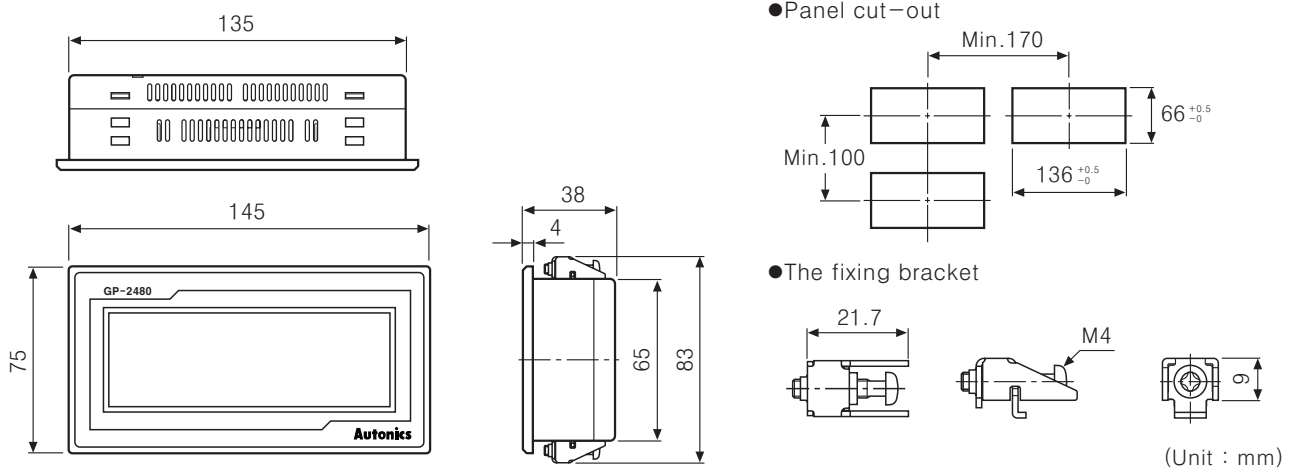

Part description

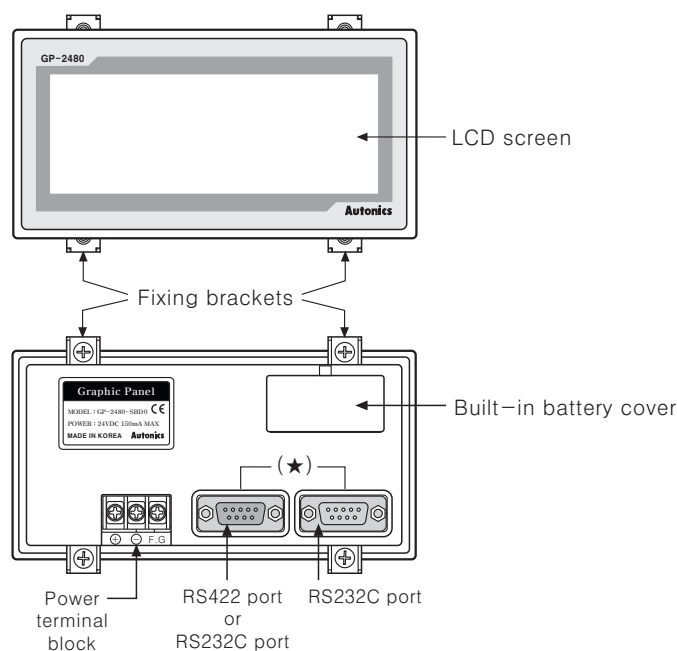

Installation

1. Set a rubber waterproof ring in GP.
2. Set GP in panel.
3. Set brackets in 4 bracket slots and fix them.

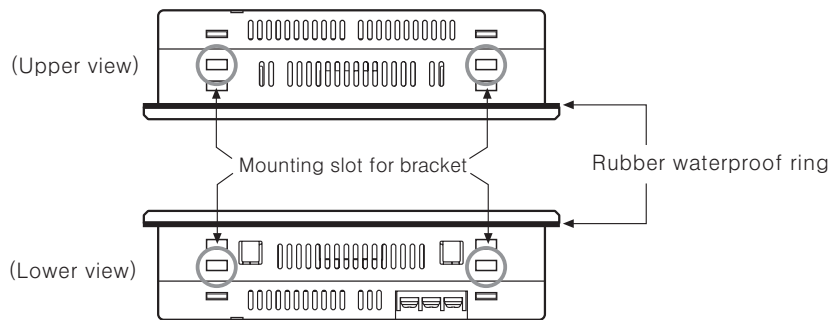

● Mounting bracket

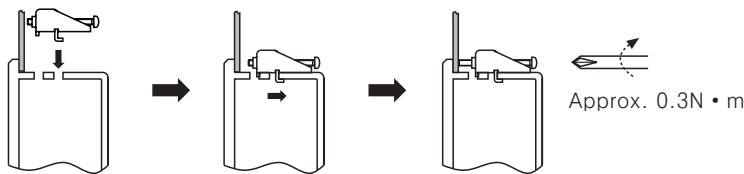

Connection wiring

- Please use at least 0.75mm² power wire, at least 1.25mm² ground wire.
- Please use crimp-on type ring terminal with min.3mm of inside diameter and max. 6mm of external diameter.
- Please make sure the power is OFF before connect the power wire.
- Please check power polarity.
- Please tighten screws of each terminal with 0.5~0.8 N · m torque.
- Ground resistance should be max.100Ω, it is required to ground separately.

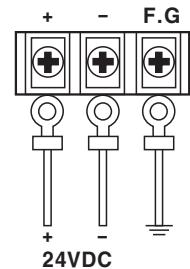

Serial interface

- Connectable devices including PC, PLC, Serial printer, barcode reader and various controllers can be connected to RS232C, RS422.
- Set the device connected into the port in system configuration. Refer to "GP user manual" for the details and "Communication manual" for connection of PLC.

Port	PIN		Port	PIN	
RS232C-A, RS232C-B D-Sub 9Pin Male	1	Non-used	RS422-A D-Sub 9Pin Female	1	TXD+
	2	RXD		2	RXD+
	3	TXD		3	RTS-
	4	DTR		4	CTS+
	5	SG		5	SG
	6	DSR		6	TXD-
	7	Non-used		7	RXD-
	8	Non-used		8	RTS+
	9	Non-used		9	CTS-

Software(GP Editor)

Please visit our website(www.autonics.com) and download software and manual.

< Computer specification for using software >

Item	Minimum specification	Recommended specification
System	Pentium II	Min. Pentium III
Memory	64MB	Min. 128MB
Hard disk	Over 50MB of available space	Over 100MB of available space
Resolution	800 × 600	Min. 800 × 600
Operating system	Windows 98/NT/2000/Me/XP	

Manual

● GP user manual

Refer to "GP user manual" for more information about design screen data using GP Editor and instructions of GP.

● Communication manual

Refer to "Communication manual" for more information about serial connection of external device, such as PLC.

Battery replacement

Please contact out distributor to replace battery. It may cause an explosion or a fire when improper battery is used.

(A) Counter

(B) Timer

(C) Temp. controller

(D) Power controller

(E) Panel meter

(F) Tacho/ Speed/ Pulse meter

(G) Display unit

(H) Sensor controller

(I) Switching power supply

(J) Proximity sensor

(K) Photo electric sensor

(L) Pressure sensor

(M) Rotary encoder

(N) 5-Phase stepping motor & Driver & Controller

(O) Graphic panel

(P) Production stoppage models & replacement

GP-2480 Series

■ Connectable device with GP

Series	Connectable device	Connection type
LG Master-K	MK-10S1	Loader
	MK-80S	Loader
	MK-120S	Loader
	MK-200S	Loader
LG Glofa	GM4	Loader
	GM6	Loader
LG CNET	MK-80S	Cnet
	MK-120S	Cnet
	MK-200S	Cnet
SAMSUNG FARA	N70	Loader
	N70Plus	Loader
MITSUBISHI FX	FX1S	Loader
	FX1N	Loader
	FX2N	Loader
	FX2NC	Loader
NAIS FP	FP0-C10	Loader
	FP0-C14	Loader
	FP0-C16	Loader
	FP0-C32	Loader
	FPG-C24R2	Loader
	FPG-C32T	Loader
OMRON SYSMAC C	CPM1A	Loader
OMRON temperature controller	E5AN	Modbus
	E5AR	Modbus
	E5CN	Modbus
	E5EN	Modbus
	E5ER	Modbus
DELTA temperature controller	DTB Series	Modbus
AUTONICS	MT Series	Private communication
	MP Series	Private communication
	THD Series	Modbus
	TZ/TZN Series	Private communication
UNIVERSAL	UNIVERSAL	Modbus(Slave)

※ The above list is available in GP Editor 2.50.

※ The connectable device will be upgraded according to GP Editor version and additional Patch. Check the latest version on our website(www.autonics.com).

※ The available version of GP firmware is different according to GP Editor version. The GP system can be down if non-compatible version is used.

※ Refer to the website(www.autonics.com) and manual to select communication cable between GP and controllers (Sold separately).

■ Application

◎ Complicated environment of operation and control

It graphicalzes mechanical control components such as button, switch and lamps so that saves cost and space and improves the preservation of devices.

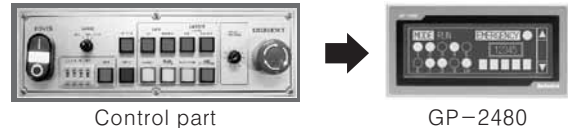

◎ Setting and change of production process

It memorizes the set conditions (Recipe) of process in GP, and it sets or changes commands to PLC without PC. It enhances reliability of production line with fast corresponding alarm of error and preserving the history.

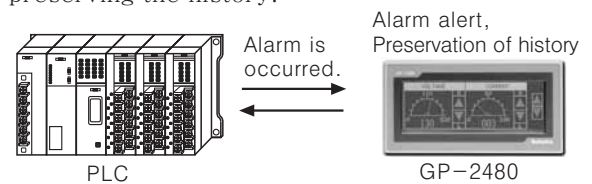

◎ Controllers with complicated setting

It sets complicated or non-displaying controller (Thermometer/hygrometer, temperature controller etc).

1) Temperature/Humidity without display device



2) Temperature controller

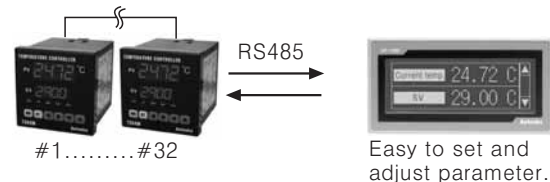

◎ Data control

It prints alarm history of controller using printer. It reads the data from barcode reader and save it in PLC.

1) PLC/Printer

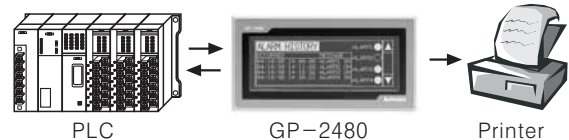

2) Barcode reader/PLC



◎ Communication between heterogeneous controllers

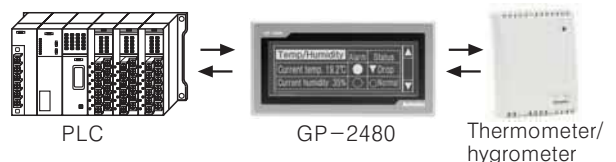

■ Precaution for using

1. Do not press touch panel with hard and sharp object.
2. Please store the device in the recommended temperature range, or LCD panel can be damaged.
3. Please check pin number shown in "Communication manual" when connect communication port.
4. Do not block the ventilating opening of this product.
5. Do not use or store it in a place with direct ray of light or dust.
6. Do not use or store it in a place with shock or vibration.
7. The ground wire of GP should be grounded separately. The ground resistance should be max.100Ω, please use the wire of min.2mm² dimension.
8. Please check the pin number and connect to GP communication port.
9. Please tighten bolt on terminal block with specified tightening torque.
10. When liquid crystal from the broken LCD is smeared on your skin, wash it for 15 minutes. If it is gotten in your eye, wash it for 15 minutes and contact a medical specialist for more information.
11. Do not inflow dust or wire dregs into the unit.
12. For cleaning, do not use water or an oil-based detergent, use dry towels.
13. It should be done away regarded as an industrial waste.

(A)
Counter

(B)
Timer

(C)
Temp.
controller

(D)
Power
controller

(E)
Panel
meter

(F)
Tacho/
Speed/
Pulse
meter

(G)
Display
unit

(H)
Sensor
controller

(I)
Switching
power
supply

(J)
Proximity
sensor

(K)
Photo
electric
sensor

(L)
Pressure
sensor

(M)
Rotary
encoder

(N)
5-Phase
stepping
motor &
Driver &
Controller

(O)
Graphic
panel

(P)
Production
stoppage
models &
replacement