

### FEATURES

- The indicating lights are the standard equipment.
- Coil screws are especially designed to prevent shocks.
- Electrical connections are with joint box type and hirschmann din type plug-in connector.
- Join box is of waterproof and dust-resistance.
- The space for electrical connections is large enough for connection layout.
- Electrical connection points are aligned with the axial direction to be compatible with modular system.
- For ease of installation and repair, the valve mounting screws are on the outside of the body.
- To sustain high pressure up to 315 kgf/cm<sup>2</sup> (4500 psi), allows for large flow rates up to 120 lpm (32 gpm).
- The ideal design of flow passages will minimize the pressure drop.
- The 4-way 4-land constructure design is applied, for reducing the flow force and system surging pressure.
- To sustain high back pressure up to 160 kgf/cm<sup>2</sup> (2350 psi)
- Manufactured with unified specifications allows for parts and accessories interchangeably.
- Viton seal kits are available for five-resistance fluids.

### HOW TO ORDER

#### SWH - G03 - C2 - A220 - 10 - LS

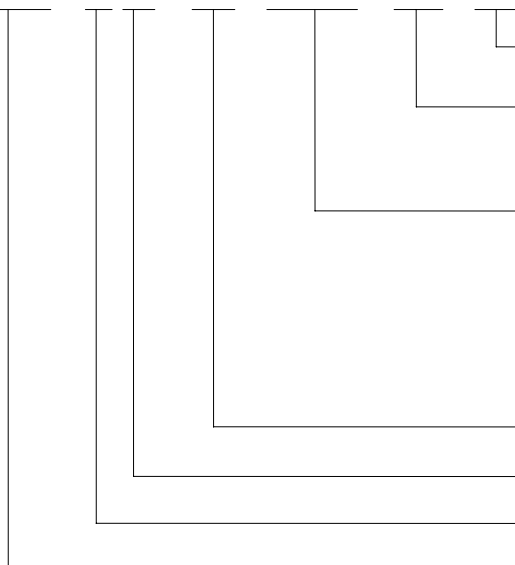

NO CODE : STANDARD  
 LS: LOW SURGE VOLTAGE( See page 8/10)  
 WIRING:  
 10: WITH JOINTION BOX  
 20: HIRSCHMANN TYPE WITH INDICATING LIGHT

COIL VOLTAGE:  
 A240: AC240V, 60Hz; AC220V, 50Hz  
 A220: AC220V, 60Hz; AC200V, 50Hz      R220: AC220V, 50/60Hz  
 A120: AC120V, 60Hz; AC110V, 50Hz  
 A110: AC110V, 60Hz; AC100V, 50Hz      R110: AC110V, 50/60Hz  
 D24: DC24V  
 D12: DC12V

SPOOL TYPE (See Application Common Data)

NOMINAL SIZE: 3/8" (D05)

SUBPLATE MOUNTED

HIGH PRESSURE HIGH FLOW SOLENOID DIRECTIONAL VALVE

# SOLENOID OPERATED DIRECTIONAL VALV

SWH-G03 SERIES

## SPECIFICATIONS

Maximum operating pressure	315 kgf/cm <sup>2</sup> (4500 PSI)
Maximum flow capacity	120 LPM (32 GPM)
Maximum tank line back pressure	160 kgf/cm <sup>2</sup> (2350 PSI)
Maximum frequencies of operation	240 CPM
Recommended filtration	25 Micron
Hydraulic fluids	Mineral oil, recommendation temperature 0-55°C Max. temperature range -25°C ~ 90°C Viscosity 10-400 cSt

## SOLENOID RATINGS

ELECTRI C SOURCE	COIL TYPE	VOLTAGE (V)			CURRENT & POWER AT RATED VOLTAGE			
		Hz	SOURCE RATED	RANGE	IN-RUSH CURRENT (A)	HOLDING CURRENT (A)	WATTAGE	
A.C.	A110	50	AC100V	90-110	4.79	0.86		
		60	AC100V	90-110	3.71	0.62		
			AC110V	99-121	4.2	0.74		
	A120	50	AC110V	99-121	4.29	0.78		
		60	AC120V	108-132	3.99	0.70		
	A220	50	AC200V	180-220	2.31	0.42		
			AC200V	180-220	1.87	0.31		
		60	AC220V	198-252	2.05	0.36		
	A240	50	AC220V	198-242	2.04	0.37		
		60	AC240V	216-264	1.88	0.33		
	R110	50	AC100V	90-110	0.47	0.47		46
		60	AC110V	99-121	0.47	0.47		46
	R220	50	AC200V	180-220	0.24	0.24		46
		60	AC220V	198-252	0.24	0.24		46
D.C.	D12	DC12V		10.8-13.2	2.58	2.58	32	
	D24	DC24V		21.6-26.4	1.33	1.33	32	

### TECHNICAL DATA:

- Solenoid can be used within - 10% to + 10% of the rated voltage of the coil.
- Withstand voltage 1500 v/sec.
- Insulation resistance over 100MΩ.

### ACCESSORIES:

- Mounting bolt kits are supplied with valve socket head cap screws M 6 x 35L 4 pieces (1/4"-20UNC x 1<sup>3</sup>/<sub>8</sub>" L) for tightening torque 120-150 kgf-cm. (104-130 lbs-in)
- O-ring AS568-014 5 pieces.

**PRESSURE DROP AND PERFORMANCE CURVES**

**TEST SYSTEM**

- 1. Testing Valve
- 2. Pump
- 3. Pressure Sensor
- 4. Flow Sensor
- 5. Relief Valve
- 6. Throttle Valve

**TEST CONDITIONS**

Pressure: 70kgf/cm<sup>2</sup>(1000PSI)  
 Flow Rate: 140 LPM (370GPM)  
 Viscosity: 35 cSt

**TEST CIRCUIT**

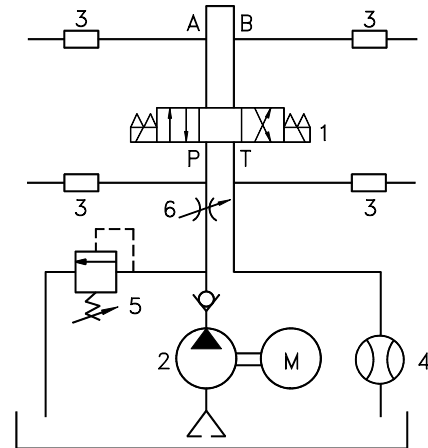

**PERFORMANCE CURVES**

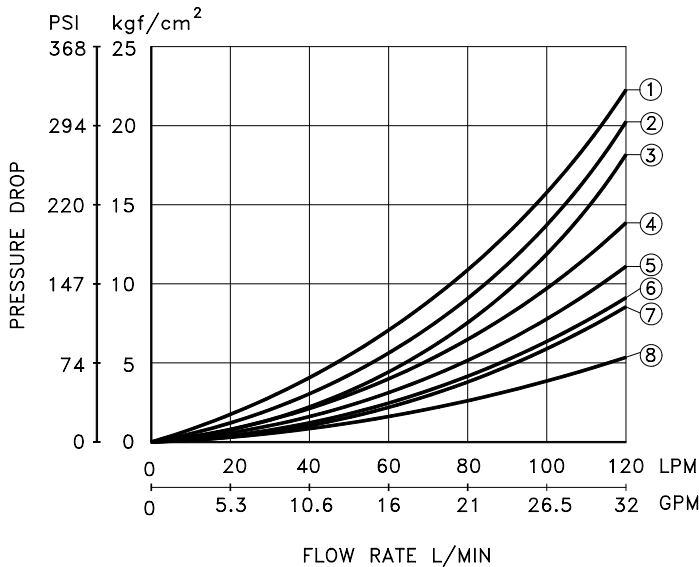

SPOOL TYPE	Pressure Drop Curve Number				
	P→A	B→T	P→B	A→T	P→T
C2	6	6	6	6	-
C3	7	7	7	7	5
C4	6	7	6	7	-
C40	6	7	6	7	-
C5	5	2	2	5	8
C6	2	2	2	2	5
C60	1	1	1	1	4
C7	7	6	7	6	-
C8	6	6	6	7	-
C9	7	6	6	6	-
B2	2	2	6	6	-
B3	3	3	6	6	-
B20	5	-	5	-	-
B2S	6	6	2	2	-
B3S	6	6	3	3	-
B20S	5	-	5	-	-

**CONTRAST CHART BETWEEN FACTORS AND VISCOSITIES**

VISCOSITY	CST	15	20	30	40	50	60	70	80	90	100
	SSU		77	98	141	186	232	278	324	371	417
FACTOR(G')		0.81	0.87	0.96	1.03	1.09	1.14	1.19	1.23	1.27	1.30

The pressure drop ( $\Delta P'$ ) can be obtained from the formula

$\Delta P' = \Delta P (G' / 0.85)$  for other specific gravity (G')

# SOLENOID OPERATED DIRECTIONAL VALV

SWH-G03 SERIES

## LIST OF SPOOL FUNCTION

THE MAXIMUM FLOW RATE LPM(GPM) UNDER DIFFERENT PRESSURE KGF/CM <sup>2</sup> (PSI) SWH G03 AC TYPE								
SPOOL TYPE NORMAL POSITION							P->>B	
	50kgf/cm <sup>2</sup> (735 PSI)	100 kgf/cm <sup>2</sup> (1470 PSI)	150 kgf/cm <sup>2</sup> (2200 PSI)	210 kgf/cm <sup>2</sup> (3000 PSI)	250 kgf/cm <sup>2</sup> (3675 PSI)	315 kgf/cm <sup>2</sup> (4500 PSI)	50kgf/cm <sup>2</sup> (735 PSI)	100 kgf/cm <sup>2</sup> (1470 PSI)
C2 	100(26.4)	100(26.4)	100(26.4)	100(26.4)	100(26.4)	100(26.4)	100(26.4)	54(14.3) 38(10.0)
C3 	100(26.4)	100(26.4)	100(26.4)	100(26.4)	100(26.4)	100(26.4)	100(26.4)	100(26.4)
C4 	100(26.4)	100(26.4)	100(26.4)	100(26.4)	100(26.4)	100(26.4)	100(26.4)	54(14.3) 42(11.1)
C40 	100(26.4)	100(26.4)	100(26.4)	100(26.4)	100(26.4)	100(26.4)	100(26.4)	100(26.4) 75(19.8)
C5 	88(23.2)	88(23.2)	88(23.2)	88(23.2)	88(23.2)	-	100(26.4)	100(26.4)
	82(21.7)	82(21.7)	82(21.7)	82(21.7)	82(21.7)			
C6 	84(22.2)	84(22.2)	84(22.2)	84(22.2)	84(22.2)	-	100(26.4)	100(26.4)
	75(19.8)	75(19.8)	75(19.8)	75(19.8)	75(19.8)			
C7 	100(26.4)	100(26.4)	100(26.4)	100(26.4)	100(26.4)	100(26.4)	63(16.6)	63(16.6)
C8 	100(26.4)	100(26.4)	100(26.4)	44(11.6)	30(7.9)	19(5.0)	100(26.4)	100(26.4)
			76(20.1)	28(7.4)	21(5.5)	14(3.7)		53(14.0)
C9 	100(26.4)	100(26.4)	100(26.4)	100(26.4)	100(26.4)	100(26.4)	57(15.1)	57(15.1)
B2 	90(23.8)	90(23.8)	90(23.8)	90(23.8)	90(23.8)	90(23.8)	63(16.6)	63(16.6)
	72(19.0)	72(19.0)	72(19.0)	72(19.0)	72(19.0)	72(19.0)		
B3 	89(23.5)	89(23.5)	89(23.5)	89(23.5)	89(23.5)	89(23.5)	100(26.4)	100(26.4)
	81(21.4)	81(21.4)	81(21.4)	81(21.4)	81(21.4)	81(21.4)		
B20 	-	-	-	-	-	-	81(21.4)	29(7.7)
D2 	100(26.4)	100(26.4)	100(26.4)	100(26.4)	100(26.4)	100(26.4)	60(15.9)	40(10.6)
D3 	100(26.4)	100(26.4)	100(26.4)	100(26.4)	100(26.4)	100(26.4)	70(18.5)	60(15.9)

NOTTE: The figures in the square shows the parameter among voltage & flow under saturated temperature and 90% applied voltage.



# SOLENOID OPERATED DIRECTIONAL VALVE



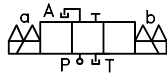
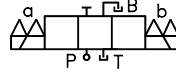







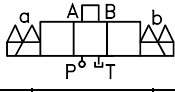
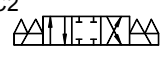

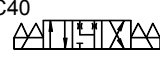
SWH-G03 SERIES

				P->B 					
150 kgf/cm <sup>2</sup> (2200 PSI)	210 kgf/cm <sup>2</sup> (3000 PSI)	250 kgf/cm <sup>2</sup> (3675 PSI)	315 kgf/cm <sup>2</sup> (4500 PSI)	50kgf/cm <sup>2</sup> (735 PSI)	100 kgf/cm <sup>2</sup> (1470 PSI)	150 kgf/cm <sup>2</sup> (2200 PSI)	210 kgf/cm <sup>2</sup> (3000 PSI)	250 kgf/cm <sup>2</sup> (3675 PSI)	315 kgf/cm <sup>2</sup> (4500 PSI)
40(10.6)	28(7.4)	25(6.6)	20(5.3)	100(26.4)	54(14.3)	40(10.6)	28(7.4)	25(6.6)	20(5.3)
27(7.1)	17(4.5)	13(3.4)	10(2.6)		38(10.0)	27(7.1)	17(4.5)	13(3.4)	10(2.6)
100(26.4)	100(26.4)	100(26.4)	100(26.4)	100(26.4)	100(26.4)	100(26.4)	100(26.4)	100(26.4)	100(26.4)
30(7.9)	23(6.1)	18(4.8)	14(3.7)	100(26.4)	54(14.3)	30(7.9)	23(6.1)	18(4.8)	14(3.7)
27(7.1)	16(4.2)	11(2.9)	8(2.1)		42(11.1)	27(7.1)	16(4.2)	11(2.9)	8(2.1)
33(8.7)	28(7.4)	22(5.8)	18(4.8)	100(26.4)	100(26.4)	33(8.7)	28(7.4)	22(5.8)	18(4.8)
23(6.1)	21(5.5)	15(4.0)	12(3.2)		75(19.8)	23(6.1)	21(5.5)	15(4.0)	12(3.2)
100(26.4)	100(26.4)	100(26.4)	-	100(26.4)	100(26.4)	100(26.4)	100(26.4)	100(26.4)	100(26.4)
100(26.4)	100(26.4)	100(26.4)	-	100(26.4)	100(26.4)	100(26.4)	100(26.4)	100(26.4)	-
95(25.1)	95(25.1)	95(25.1)		95(25.1)	95(25.1)	95(25.1)	95(25.1)	95(25.1)	
63(16.6)	63(16.6)	63(16.6)	63(16.6)	63(16.6)	63(16.6)	63(16.6)	63(16.6)	63(16.6)	63(16.6)
37(9.8)	34(9.0)	28(7.4)	20(5.3)	100(26.4)	61(16.1)	33(8.7)	27(7.1)	20(5.3)	16(4.2)
32(8.5)	28(7.4)	21(5.5)	15(4.0)		48(12.7)	27(7.1)	21(5.5)	15(4.0)	9(2.4)
57(15.1)	57(15.1)	57(15.1)	57(15.1)	100(26.4)	53(14.0)	47(12.4)	45(11.9)	40(10.6)	34(9.0)
					40(10.6)	37(9.8)	34(9.0)	29(7.7)	25(6.6)
63(16.6)	63(16.6)	63(16.6)	63(16.6)	100(26.4)	78(20.6)	45(11.9)	43(11.4)	38(10.0)	32(8.5)
					74(19.6)	38(10.0)	36(9.5)	31(8.2)	27(7.1)
100(26.4)	100(26.4)	100(26.4)	100(26.4)	100(26.4)	100(26.4)	95(25.1)	82(21.7)	75(19.8)	65(17.2)
					89(23.5)	84(22.2)	77(20.3)	70(18.5)	62(16.4)
19(5.0)	12(3.2)	9(2.4)	7(1.8)	100(26.4)	80(21.1)	32(8.5)	25(6.6)	20(5.3)	14(3.7)
					42(11.1)	28(7.4)	22(5.8)	17(4.5)	12(3.2)
40(10.6)	40(10.6)	30(7.9)	28(7.4)	60(15.9)	40(10.6)	40(10.6)	40(10.6)	30(7.9)	28(7.4)
60(15.9)	60(15.9)	42(11.1)	36(9.5)	70(18.5)	60(15.9)	60(15.9)	60(15.9)	42(11.1)	36(9.5)

# SOLENOID OPERATED DIRECTIONAL VALV

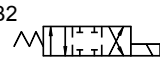
SWH-G03 SERIES

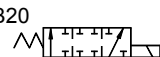
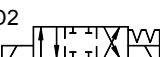
## LIST OF SPOOL FUNCTION

THE MAXIMUM FLOW RATE LPM(GPM) UNDER DIFFERENT PRESSURE KGF/CM <sup>2</sup> (PSI) SWH G03 DC TYPE								
SPOOL TYPE NORMAL POSITION	P→>A,B→>T P→>B,A→>T						P→>A	
	50kgf/cm <sup>2</sup> (735 PSI)	100 kgf/cm <sup>2</sup> (1470 PSI)	150 kgf/cm <sup>2</sup> (2200 PSI)	210 kgf/cm <sup>2</sup> (3000 PSI)	250 kgf/cm <sup>2</sup> (3675 PSI)	315 kgf/cm <sup>2</sup> (4500 PSI)	50kgf/cm <sup>2</sup> (735 PSI)	100 kgf/cm <sup>2</sup> (1470 PSI)
C2 	120(31.7)	120(31.7)	120(31.7)	120(31.7)	120(31.7)	120(31.7)	120(31.7)	120(31.7) 100(26.4)
C3 	120(31.7)	120(31.7)	120(31.7)	120(31.7)	120(31.7)	120(31.7)	120(31.7)	120(31.7)
C4 	120(31.7)	120(31.7)	120(31.7)	120(31.7)	120(31.7)	120(31.7)	120(31.7)	120(31.7) 100(26.4)
C40 	120(31.7)	120(31.7)	120(31.7) 100(26.4)	97(25.6) 75(19.8)	78(20.6) 54(14.3)	60(15.9) 41(10.8)	120(31.7)	120(31.7) 115(30.4)
C5 	100(26.4)	100(26.4)	100(26.4)	100(26.4)	100(26.4)	100(26.4)	100(26.4)	100(26.4)
C6 	100(26.4)	100(26.4)	100(26.4)	100(26.4)	100(26.4)	100(26.4)	100(26.4)	100(26.4)
C7 	120(31.7)	120(31.7)	120(31.7)	120(31.7)	120(31.7)	120(31.7)	65(17.2)	65(17.2)
C8 	120(31.7)	120(31.7)	120(31.7) 100(26.4)	97(25.6) 85(22.5)	78(20.6) 54(14.3)	66(17.4) 41(10.8)	120(31.7)	120(31.7)
C9 	120(31.7)	120(31.7)	120(31.7)	120(31.7)	120(31.7)	120(31.7)	65(17.2)	65(17.2)
B2 	95	95	95	95	95	95	69(18.2)	69(18.2)
B3 	89(23.5)	89(23.5)	89(23.5)	89(23.5)	89(23.5)	89(23.5)	120(31.7)	120(31.7)
B20 	-	-	-	-	-	-	85(22.5)	35(9.2)
D2 	120(31.7)	120(31.7)	120(31.7)	120(31.7)	120(31.7)	120(31.7)	60(15.9)	40(10.6)
D3 	120(31.7)	120(31.7)	120(31.7)	120(31.7)	120(31.7)	120(31.7)	70(18.5)	60(15.9)



# SOLENOID OPERATED DIRECTIONAL VALVE

SWH-G03 SERIES

				P->B					
150 kgf/cm <sup>2</sup> (2200 PSI)	210 kgf/cm <sup>2</sup> (3000 PSI)	250 kgf/cm <sup>2</sup> (3675 PSI)	315 kgf/cm <sup>2</sup> (4500 PSI)	50kgf/cm <sup>2</sup> (735 PSI)	100 kgf/cm <sup>2</sup> (1470 PSI)	150 kgf/cm <sup>2</sup> (2200 PSI)	210 kgf/cm <sup>2</sup> (3000 PSI)	250 kgf/cm <sup>2</sup> (3675 PSI)	315 kgf/cm <sup>2</sup> (4500 PSI)
73(19.3)	63(16.6)	54(14.3)	37(9.8)	120(31.7)	120(31.7)	73(19.3)	63(16.6)	54(14.3)	37(9.8)
55(14.5)	48(12.7)	38(10.0)	29(7.7)		100(26.4)	55(14.5)	48(12.7)	38(10.0)	29(7.7)
120(31.7)	120(31.7)	120(31.7)	120(31.7)	120(31.7)	120(31.7)	120(31.7)	120(31.7)	120(31.7)	120(31.7)
90(23.8)	73(19.3)	60(15.9)	47(12.4)	120(31.7)	120(31.7)	90(23.8)	73(19.3)	60(15.9)	47(12.4)
78(20.6)	64(16.9)	51(13.5)	39(10.3)		100(26.4)	78(20.6)	64(16.9)	51(13.5)	39(10.3)
75(19.8)	54(14.3)	42(11.1)	37(9.8)	120(31.7)	120(31.7)	75(19.8)	54(14.3)	42(11.1)	37(9.8)
50(13.2)	39(10.3)	30(7.9)	21(5.5)		115(30.4)	50(13.2)	39(10.3)	30(7.9)	21(5.5)
100(26.4)	100(26.4)	100(26.4)	-	100(26.4)	100(26.4)	100(26.4)	100(26.4)	100(26.4)	-
100(26.4)	100(26.4)	100(26.4)	-	100(26.4)	100(26.4)	100(26.4)	100(26.4)	100(26.4)	-
65(17.2)	65(17.2)	65(17.2)	65(17.2)	65(17.2)	65(17.2)	65(17.2)	65(17.2)	65(17.2)	65(17.2)
68(18.0)	51(13.5)	37(9.8)	27(7.1)	120(31.7)	85(22.5)	50(13.2)	36(9.5)	25(6.6)	19(5.0)
52(13.7)	39(10.3)	28(7.4)	18(4.8)		65(17.2)	40(10.6)	28(7.4)	15(4.0)	12(3.2)
65(17.2)	65(17.2)	65(17.2)	65(17.2)	120(31.7)	100(26.4)	94(24.8)	85(22.5)	76(20.1)	70(18.5)
					85(22.5)	80(21.1)	74(19.6)	54(14.3)	49(12.9)
69(18.2)	69(18.2)	69(18.2)	69(18.2)	120(31.7)	120(31.7)	77(20.3)	63(16.6)	57(15.1)	45(11.9)
						66(17.4)	55(14.5)	44(11.6)	38(10.0)
120(31.7)	120(31.7)	120(31.7)	120(31.7)	100(26.4)	100(26.4)	95(25.1)	82(21.7)	75(19.8)	65(17.2)
					89(23.5)	84(22.2)	77(20.3)	70(18.5)	62(16.4)
28(7.4)	19(5.0)	15(4.0)	10(2.6)	120(31.7)	120(31.7)	95(25.1)	74(19.6)	61(16.1)	43(11.4)
					95(25.1)	84(22.2)	63(16.6)	50(13.2)	34(9.0)
40(10.6)	40(10.6)	30(7.9)	28(7.4)	60(15.9)	40(10.6)	40(10.6)	40(10.6)	30(7.9)	28(7.4)
60(15.9)	60(15.9)	42(11.1)	36(9.5)	70(18.5)	60(15.9)	60(15.9)	60(15.9)	42(11.1)	36(9.5)

# SOLENOID OPERATED DIRECTIONAL VALV

SWH-G03 SERIES

## RESULT OF MEASUREMENTS

### TEST SYSTEMS

1. Testing Valve
2. Pump
3. Pressure Sensor
4. Flow Meter
5. Relief Valve
6. Throttle Valve

### TEST CONDITIONS

Pressure: 160 kgf/cm<sup>2</sup> (2350 PSI)  
 Flow Rate: 140 LPM (37 GPM)  
 Viscosity: 35 cSt

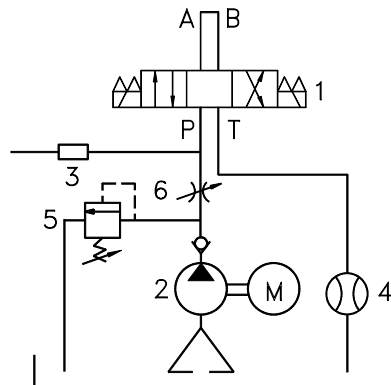

MODEL	SHIFT OVER TIME (SEC)	
	T 1	T 2
SWH-G03-AC SERIES	0.02	0.02
SWH-G03-DC SERIES	0.07	0.07
SWH-G03-RF SERIES	0.07	0.07

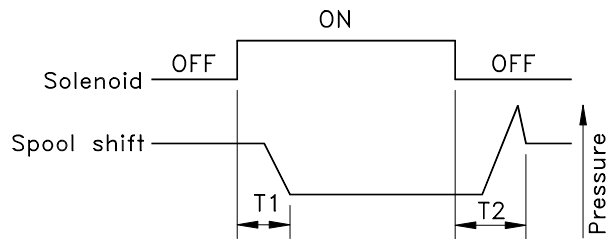

## OPTION LS

Electrical Surge Control Model

### OPTION LS

Valve model: SWH-G03-\*\*\*-D\*\*\*-LS

### FEATURES

- Suppresses the surge voltage.
- Eliminates sparks between relay contacts.
- Extends the life of the relay contact.

### Effects

- Improves the reliability of the control relay.
- Extends the life of conventional relays.
- Can be operated with a miniature relay.
- The RAC rectifier built-in DC model eliminate sparks at the control relay contact. It can be directly operated with a PLC (programmable logic controller).

Electrical surge waveform standard DC Solenoid.

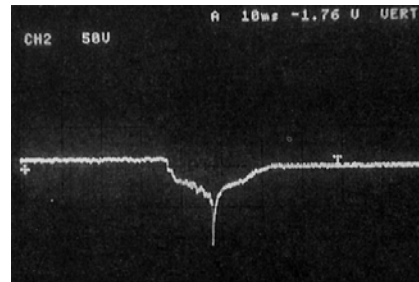

Electrical surge controlled DC solenoid.

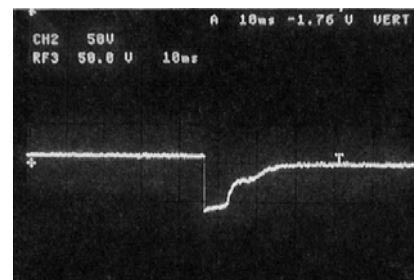





# SOLENOID OPERATED DIRECTIONAL VALVE

## SWH-G03 SERIES

### INSTALLATION DIMENSIONS

Mounting Surface: ISO 4401-AC-05-4-A

SWH-G03 -\*\*\*-A\*\*\*-10-\*\*  
Models with AC solenoids

UNIT:mm(inch)

MODEL	WEIGHT kgs(lb)
SWH-G03-C**-A***-10	4.1(9.02)
SWH-G03-B**-A***-10	3.4(7.48)

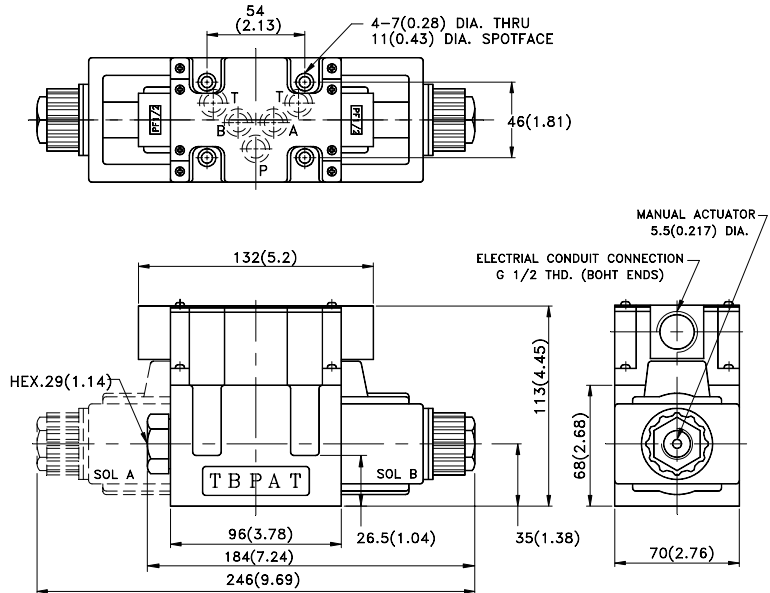

SWH-G03 -\*\*\*-\*\*\*\*-10-\*\*  
Models with Dc, RF solenoids

MODEL	WEIGHT kgs(lb)
SWH-G03-C**-D**-10	5.5(12.1)
SWH-G03-C**-R***-10	
SWH-G03-B**-D**-10	4.0(9.68)
SWH-G03-B**-R***-10	

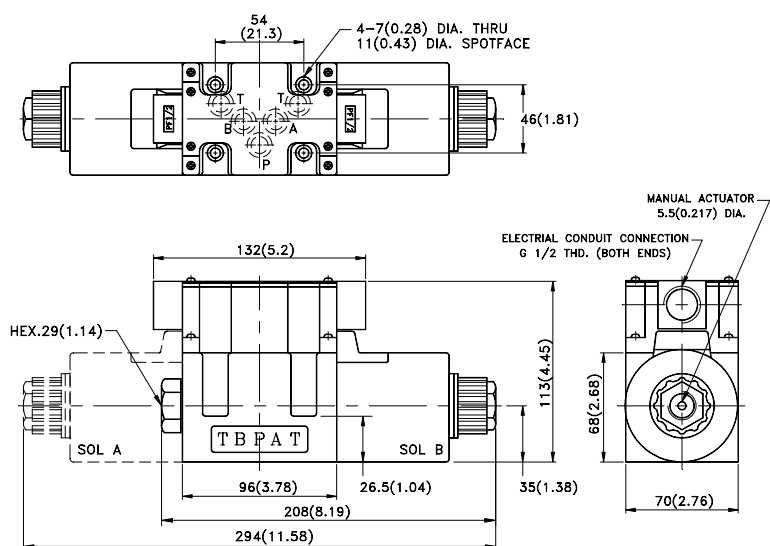

# SOLENOID OPERATED DIRECTIONAL VALV

SWH-G03 SERIES

## INSTALLATION DIMENSIONS

Mounting Surface: ISO 4401-AC-05-4-A

UNIT:mm(inch)

SWH-G03 -\*\*\*-A\*\*\*-20-\*\*\*  
Models with AC solenoids

MODEL	WEIGHT kgs(lb)
SWH-G03 -C**-A***-20	4.1(9.02)
SWH-G03 -B**-A***-20	3.4(7.48)

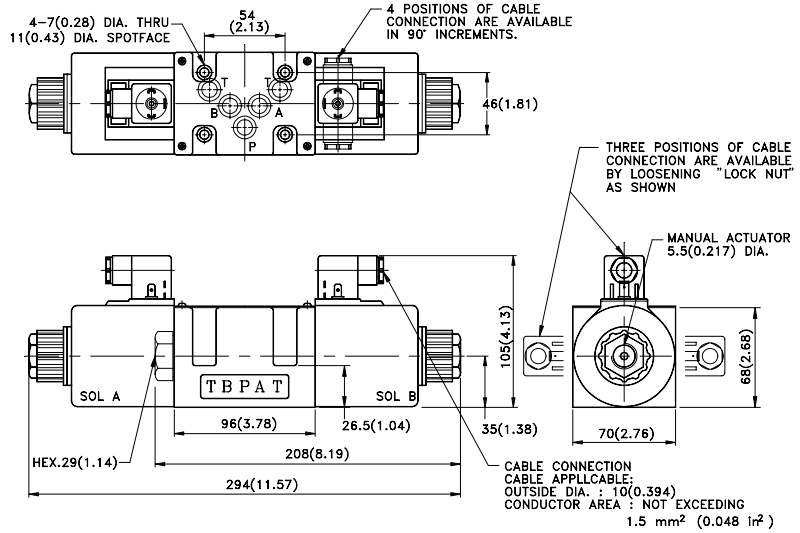

SWH-G03 -\*\*\*- \*\*\*-20-\*\*\*  
Models with DC, RF solenoids

MODEL	WEIGHT kgs(lb)
SWH-G03-C **-D **-20	5.5(12.1)
SWH-G03-C**-R ***-20	
SWH-G03-B **-D **-20	4.0(9.68)
SWH-G03-B**-R ***-20	

