

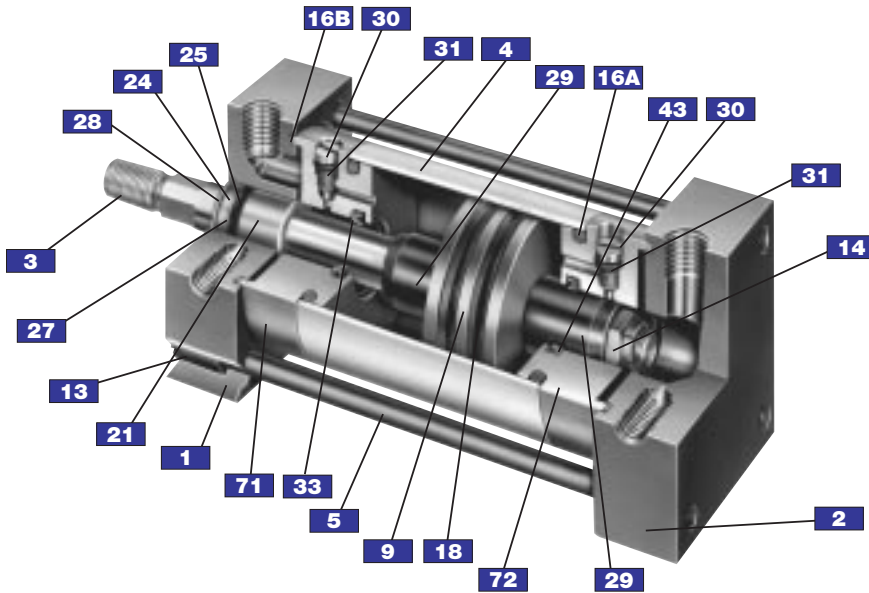

***AA SERIES
Light-Duty
Aluminum
Pneumatic
Cylinders***

Pressure Rating 200 PSI





1,2 Head and Cap

Accurately machined from aluminum bar stock and black anodized for protection and attractive appearance.

3 Piston Rod

Piston rods have a minimum expected yield of 100,000 psi. They are ground, polished, and hard chrome plated for wear and corrosion resistance. Four wrench flats are standard.

4 Tube

The tube is a high tensile, special Aluminum alloy with a hard anodized finish. The file-hard finish offers long life and amazing lubrication holding properties.

5 Tie Rods

Maximum strength is obtained through a prestressed tie rod assembly. The use of tie rods eliminates axial loading of the tube.

Pistons are machined from a fine grain

9 Piston

alloy cast iron. They are of one piece design to give full thickness bearing and engineered for fast, positive inflation of seals.

Tie Rod Torque Chart

CYLINDER BORE	TORQUE IN FOOT LBS.
1 1/2	6
2	6
2 1/2	10

16B Tube End Seals

Static seals at tube ends are confined, precision cut gaskets.

18 Piston Seals

Modified U-cup seals are Buna-N compound. They are self-adjusting to pressure and wear and their design permits simple replacement — no need to disassemble the piston from the piston rod.

The replaceable rod bearing is made of

21 Rod Bearings

oil impregnated sintered bronze for lubricated long life.

24 Rod Wiper

designed to wipe off abrasive dust and contaminants on the retract stroke to insure long life for seals, rod bearing, and piston rod. This type of wiper is efficient, has low friction, and can be replaced without disassembly of the cylinder.

25 Rod Seal

Modified U-cup design offers long life with minimum friction. It is self-adjusting to pressure and wear. Seal material is a standard Buna-N compound. The rod seal can be replaced without disassembly of the cylinder.

30 Adjusting Screw

Adjusting screw is O-Ring sealed and can be rotated to any position for easy accessibility. When shipped, cushion adjusting screws will be in positions 1 and 5 (as shown in illustration). AA SERIES cylinders can be ordered

33, 43 Cushions

with no cushions, cushioned front, cushioned rear, or cushioned both ends. A modified U-cup gives positive sealing during cushioning and free flow of air

33, 43 Cushion Seal

for rapid acceleration out of cushion. No check valve is needed. Cushion insert sandwiched between the tube and head (or cap) is sealed with a pressure-activated O-RING (16A).

71, 72 Cushion Insert

Synthetic wiper, steel encased, is

Parts List

ITEM NUMBER	DESCRIPTION	QUANTITY REQUIRED
1	HEAD AND BEARING ASSEMBLY	1
2	CAP	1
3	PISTON ROD	1
4	TUBE	1
5	TIE ROD	4
9	PISTON	1
13	SLEEVE NUT	4
14	PISTON ROD NUT	1
16A†	TUBE SEAL—O-RING	*
16B†	TUBE SEAL—GASKET	2
18†	PISTON SEAL	2
21	ROD BEARING	1
24†	ROD WIPER	1
25†	ROD SEAL	1
27	ROD SEAL SUPPORT WASHER	1
28	ROD SEAL RETAINING RING	1
29	CUSHION PISTON	**
30	CUSHION ADJUSTING SCREW	*
31†	SEAL—CUSHION ADJUSTING	*
33†	CUSHION SEAL—FRONT	*
43†	CUSHION SEAL—REAR	*
71	CUSHION INSERT—FRONT	*
72	CUSHION INSERT—REAR	*

†Recommended Spare Parts

*As required: Specify if cushioned front, cushioned rear or cushioned both ends.

**Used on all cushioned front cylinders. Used on cushioned rear cylinders bore sizes 1 1/2" and 2" only.

► Dimensions

Dimensions for Cushioned Cylinders

Adding a cushion or cushions to a cylinder increases overall length. A front cushion or rear cushion adds 1 inch to all *plus stroke* dimensions. Cushioning a cylinder on both ends adds 2 inches to all *plus stroke* dimensions.

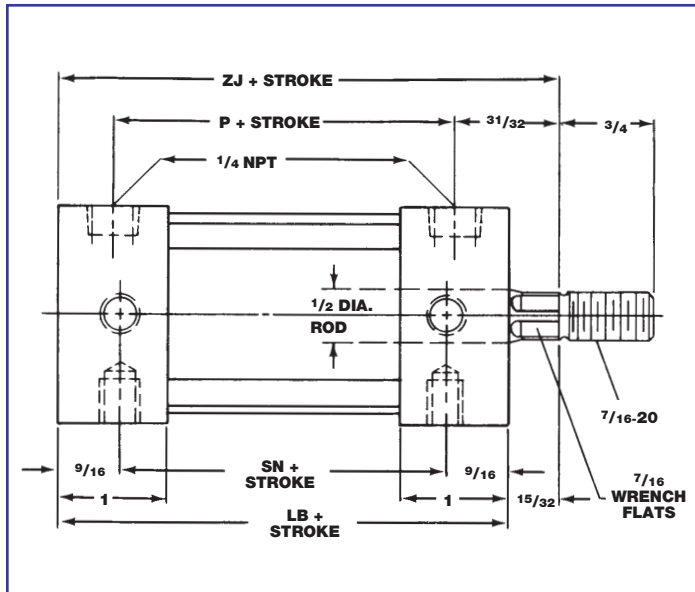

Double Rod End Cylinders

All dimensions shown below remain unchanged. Second rod (not shown in dimension drawing) will extend from face of head the total of the stroke plus $1\frac{5}{32}$ " plus the threaded rod end dimension.

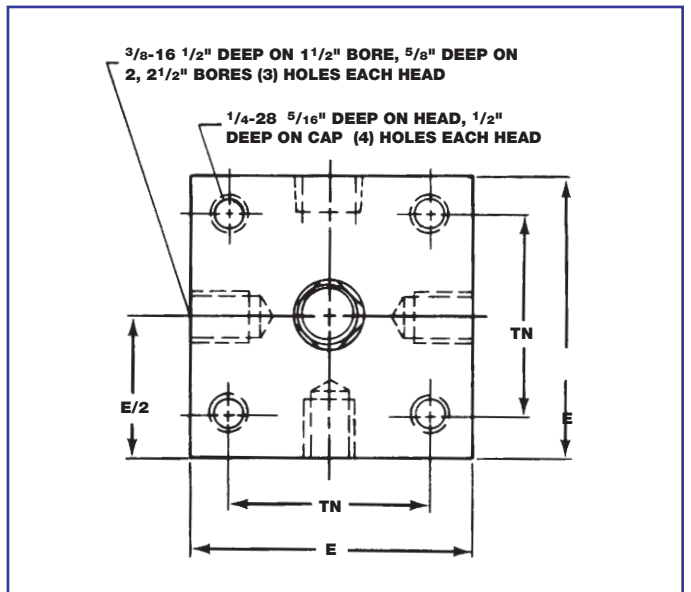

BORE	E	LB*	P*	SN*	TN	ZJ*
1 1/2	2	27/8	17/8	1 3/4	17/16	311/32
2	2 1/2	27/8	17/8	1 3/4	127/32	311/32
2 1/2	3	3	2	17/8	23/16	315/32

*Plus Stroke Dimensions

Universal Mount

The basic cylinder is equipped with Universal Mounting Holes that permit side flush mount, front head mount and rear head mount. Using optional mounting kits, shown on Page AA-3, complete versatility is achieved to satisfy any mounting requirement and to do so economically.

TP-AA Trunnion Pin Assemblies thread into $\frac{3}{8}$ -16 holes on sides of head.

NOTE: For Pivot and Clevis Bracket Mounts, use Mounting Brackets dimensioned on Page AA-3. Use $\frac{1}{4}$ -28 Cap Screws supplied to bolt brackets to rear head.

Front Flange, Rear Flange and Foot Bracket Mount use Universal Mounting Brackets (See Page AA-3).

Affix brackets by using $\frac{3}{8}$ -16 holes on sides of head and FMS-AA mounting screws.

Use $\frac{1}{4}$ -28 cap screws supplied to bolt brackets to each head as shown.

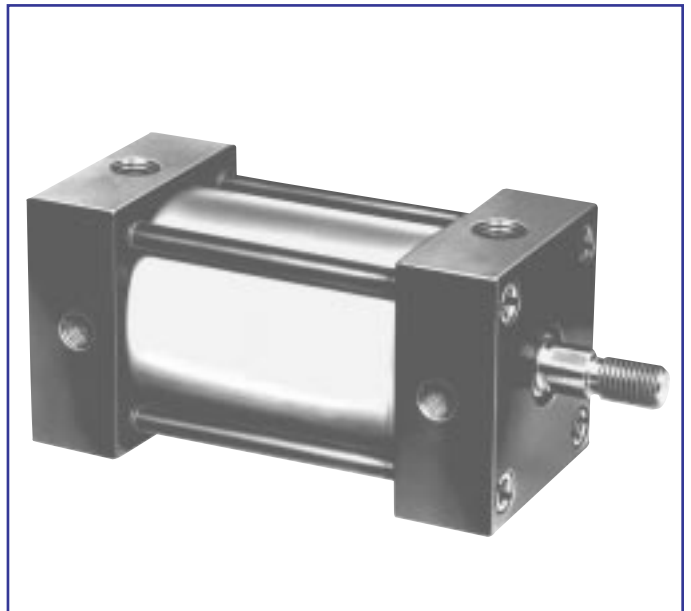

► Mountings and Mounting Accessories

FOOT BRACKET MOUNT

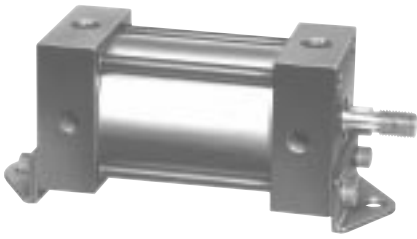

TRUNNION FRONT MOUNT

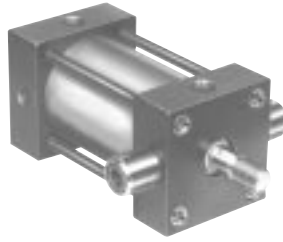

CLEVIS AND PIVOT MOUNT

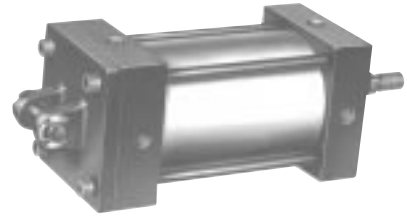

REAR FLANGE MOUNT

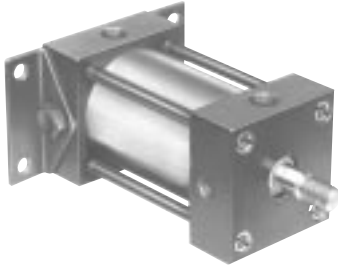

FRONT FLANGE MOUNT

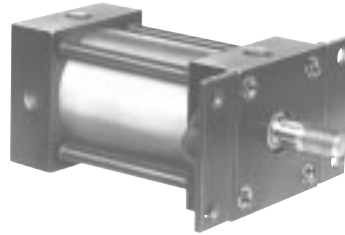

TRUNNION REAR MOUNT



UNIVERSAL MOUNTING BRACKETS WITH SCREWS

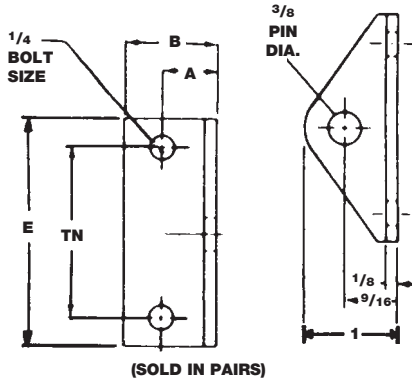

Universal Mounting Brackets

PART NO.	BORE	A	B	E	TN
UB-15	1 1/2	13/32	11/16	2	17/16
UB-20	2	19/32	29/32	2 1/2	127/32
UB-25	2 1/2	25/32	13/16	3	23/16

NOTE: To use Universal Mounting Brackets as Flange Mounts, order a pair of Flange Mounting Screws. Part No. FMS-AA.

TRUNNION MOUNTING PINS
PART NO. TP-AA

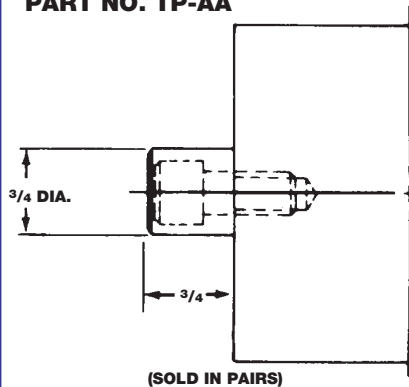

STROKE SPACERS

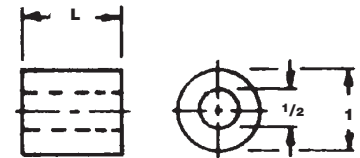

Stroke Spacers

PART NUMBER	L
SS-025	1/4 IN. LG.
SS-050	1/2 IN. LG.
SS-100	1 IN. LG.

CLEVIS AND PIVOT MOUNTING BRACKETS

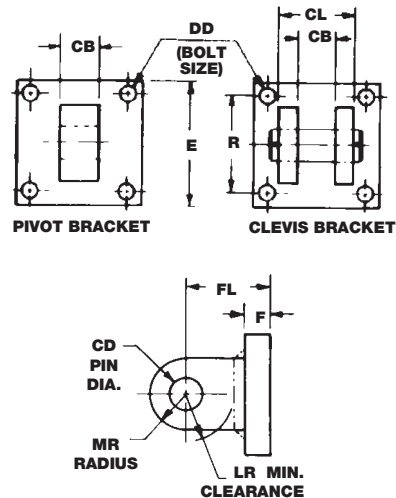

Clevis and Pivot Mounting Brackets

PART NUMBER CLEVIS	PART NUMBER PIVOT	CB	CD	CL	DD (BOLT SIZE)	E	F	FL	MR	R
1 1/2 MBC-AA	1 1/2 MBP-AA	11/16	3/8	15/16	9/32	2	5/16	15/16	3/8	17/16
2 MBC-AA	2 MBP-AA	11/16	3/8	15/16	9/32	2 1/2	5/16	15/16	3/8	127/32
2 1/2 MBC-AA	2 1/2 MBP-AA	11/16	3/8	15/16	9/32	3	5/16	15/16	3/8	23/16

NOTE: Pin and Retainer supplied with Clevis Brackets. Mounting Screws supplied with all Brackets.

Bore	Cylinder Series	Stroke	Cushion	Modification
As Required Use Fractions Where Required	A Heavy Duty Pneumatic AA 200 PSI Pneumatic CLA Heavy Duty Pneumatic CLH Heavy Duty, 250 Pneumatic/1500 Hydraulic C20 Heavy Duty Pneumatic, Cast Iron HH Heavy Duty Hydraulic MA Medium Duty Pneumatic MH Medium Pressure Hydraulic	As Required Use Fractions Where Required Shown as Gross Stroke Including Dual Piston or Stop Tube Length	CF - Cushion Front CR - Cushion Rear CC - Cushion Both Ends	A - Variation in Ports D - Double Rod Extension K - Any Variation in Rod from Standard. Any Variation from Standard Style 2 Rod End. M - Variation in Mounting P - NPT Ports S - Spring Return V - Viton Seals W - Water Fitted Y - Variation in Construction

This is a universal mount cylinder order mounting kits (page AA-3) seperately.

Order Information

To insure prompt delivery, please BE SURE TO INCLUDE THIS INFORMATION WHEN ORDERING:

- | | | |
|--|---|---|
| 1. Quantity | 8. Rod End Style (if other than Style 2 standard) | 14. Medium (air, oil, water or other) |
| 2. Series | 9. Rod Size (standard, oversize or 2:1) | 15. Type of fluid |
| 3. Bore | 10. <i>Extra</i> Rod Extension (where required) | 16. Operating Pressure and Maximum Shock Pressure |
| 4. Stroke - Gross Stroke always shown in Model Number | 11. Port Size (if other than standard) | 17. Temperature |
| 5. Dual Piston or Stop Tube when necessary - always give Gross and Net Strokes | 12. Port Positions other than standard positions 1 and 5. | 18. Double rod extension (when required) |
| 6. Mounting Style | 13. Cushion check, adjusting screw, and bleed positions (when required) if other than standard positions. | 19. XI dimension on all Trunnion (between head) cylinders |
| 7. Cushion (front, rear, both or none) | | 20. Delivery required, or scheduling |

Complete and correct ordering information will eliminate untimely delays. When in doubt, always contact local distributor or factory. Contact distributor for helpful order or inquiry form.

Policy:

The policy of the Sheffer Corporation is one of continual improvement in design and manufacture to assure still finer products, hence, specifications are subject to change without notice.

Limited Warranty:

Sheffer warrants its products to be free from defects in material and workmanship for a period of one year from the date of shipment. This warranty does not cover field labor charges for parts removal and replacement, adjustments, repairs or other work, corrosion, electrolysis, mineral deposits or normal deterioration, misapplication, modification, or change in original operating conditions; components supplied by others; defects in parts resulting from abuse, negligence, neglect, accident, fire or explosion, or seals and other components subject to normal wear.

The sole and exclusive remedy against Sheffer shall be for the repair or replacement of parts returned transportation prepaid to Sheffer's factory and found by Sheffer to be defective. Replacement parts provided shall not extend the warranty period for said parts or for the total unit.

IN CONSIDERATION OF THIS EXPRESS WARRANTY NO OTHER REMEDY (INCLUDING BUT NOT LIMITED TO INCIDENTAL OR CONSEQUENTIAL DAMAGES) SHALL BE AVAILABLE. THIS WARRANTY SHALL BE IN LIEU OF ANY AND ALL OTHER WARRANTIES, EXPRESS OR IMPLIED, INCLUDING, BUT NOT LIMITED TO, ANY IMPLIED WARRANTY OF MERCHANTABILITY OR FITNESS FOR A PARTICULAR PURPOSE, AND OF ALL OTHER OBLIGATIONS ON THE PART OF SHEFFER.

Sheffer neither assumes, nor authorizes any person to assume for it, any other obligation or warranty.

► Conversions

Fraction Equivalents

Fraction (inches)	Decimal (inches)	Metric (mm) (x 25.4)
1/64	.016	.4
1/32	.031	.8
3/64	.047	1.2
1/16	.062	1.6
5/64	.078	2.0
3/32	.094	2.4
7/64	.109	2.8
1/8	.125	3.2
9/64	.141	3.6
5/32	.156	4.0
11/64	.172	4.4
3/16	.187	4.7
13/64	.203	5.2
7/32	.219	5.6
15/64	.234	5.9
1/4	.250	6.3
17/64	.266	6.8
9/32	.281	7.1
19/64	.297	7.5
5/16	.312	7.9
21/64	.328	8.3
11/32	.344	8.7
23/64	.359	9.1
3/8	.375	9.5
25/64	.391	9.9
13/32	.406	10.3
27/64	.422	10.7
7/16	.437	11.1
29/64	.453	11.5
15/32	.469	11.9
31/64	.484	12.3
1/2	.500	12.7

Fraction (inches)	Decimal (inches)	Metric (mm) (x 25.4)
33/64	.516	13.1
17/32	.531	13.5
35/64	.547	13.9
9/16	.562	14.3
37/64	.578	14.7
19/32	.594	15.1
39/64	.609	15.5
5/8	.625	15.9
41/64	.641	16.3
21/32	.656	16.7
43/64	.672	17.1
11/16	.687	17.4
45/64	.703	17.9
23/32	.719	18.3
47/64	.734	18.6
3/4	.750	19.0
49/64	.766	19.5
25/32	.781	19.8
51/64	.797	20.2
13/16	.812	20.6
53/64	.828	21.0
27/32	.844	21.4
55/64	.859	21.8
7/8	.875	22.2
57/64	.891	22.6
29/32	.906	23.0
59/64	.922	23.4
15/16	.937	23.8
61/64	.953	24.2
31/32	.969	24.6
63/64	.984	25.0
1	1.000	25.4

Temperature Equivalents

F°	C°
-30	-34.4
-20	-28.9
-10	-23.3
0	-17.8
10	-12.2
20	-6.7
30	-1.1
40	4.4
50	10.0
60	15.6
70	21.1
80	26.7
90	32.2
100	37.8
110	43.3
120	48.9
130	54.4
140	60.0
150	65.6
160	71.1
170	76.7
180	82.2
190	87.8
200	93.3
210	98.9
220	104.4
230	110.0
240	115.6
250	121.1
260	126.7

C°	F°
-30	-22
-20	-4
-10	14
0	32
5	41
10	50
15	59
20	68
25	77
30	86
35	95
40	104
45	113
50	122
55	131
60	140
65	149
70	158
75	167
80	176
85	185
90	194
95	203
100	212
105	221
110	230
115	239
120	248
125	257
130	266

$$C^{\circ} = (F^{\circ} - 32) \div 1.8$$

$$F^{\circ} = C^{\circ} \times 1.8 + 32$$

▶ Conversions

Pressure Conversions

PSI	Kg/cm ²	Bars
60	4.2	4.1
70	4.9	4.8
80	5.6	5.5
90	6.3	6.2
100	7.0	6.9
150	10.5	10.3
200	14.0	13.8
250	17.6	17.2
300	21.1	20.7
350	24.6	24.1
400	28.1	27.6
450	31.6	31.0
500	35.1	34.4
550	38.7	37.9
600	42.2	41.3
650	45.7	44.8
700	49.2	48.2
750	52.7	51.7
800	56.2	55.1
850	59.8	58.6
900	63.3	62.0
950	66.8	65.5
1000	70.3	68.9
1500	105.5	103.4
2000	140.6	137.8
2500	175.8	172.3
3000	210.9	206.7
3500	246.1	241.2
4000	281.2	275.6
4500	316.4	310.1
5000	351.5	344.5

Kg/cm² = PSI x .0703
 Bars = PSI x .0689

Kg/cm ²	PSI	Bars
4	56.9	3.9
5	71.1	4.9
6	85.3	5.9
7	99.5	6.9
8	113.8	7.8
9	128.0	8.8
10	142.2	9.8
20	284.4	19.6
30	426.6	29.4
40	568.8	39.2
50	711.0	49.0
60	853.2	58.8
70	995.4	68.6
80	1137.6	78.4
90	1279.8	88.2
100	1422.0	98.0
150	2133.0	147.0
200	2844.0	196.0
250	3555.0	245.0
300	4266.0	294.0
350	4977.0	343.0
400	5688.0	392.0

PSI = Kg/cm² x 14.22
 Bars = Kg/cm² x .98

Distance Conversions

Inches	cm	mm
1	2.5	25.4
2	5.1	50.8
3	7.6	76.2
4	10.2	101.6
5	12.7	127.0
6	15.2	152.4
7	17.8	177.8
8	20.3	203.2
9	22.9	228.6
10	25.4	254.0
15	38.1	381.0
20	50.8	508.0
25	63.5	635.0
30	76.2	762.0
35	88.9	889.0
40	101.6	1016.0
45	114.3	1143.0
50	127.0	1270.0
55	139.7	1397.0
60	152.4	1524.0
65	165.1	1651.0
70	177.8	1778.0
75	190.5	1905.0
80	203.2	2032.0
85	215.9	2159.0
90	228.6	2286.0
95	241.3	2413.0
100	254.0	2540.0

cm = in. x 2.54
 mm = in. x 25.4

cm	Inches
1	.4
2	.8
3	1.2
4	1.6
5	2.0
6	2.4
7	2.8
8	3.1
9	3.5
10	3.9
20	7.9
30	11.8
40	15.8
50	19.7
60	23.6
70	27.6
80	31.5
90	35.5
100	39.4
110	43.3
120	47.3
130	51.2
140	55.2
150	59.1
160	63.0
170	67.0
180	70.9
190	74.9
200	78.8
210	82.7
220	86.7
230	90.6
240	94.6
250	98.5
260	102.4

in. = cm x .394



The Sheffer Corporation
6990 Cornell Road • Cincinnati, Ohio 45242
(513) 489-9770 • Fax: (513) 489-3034
www.sheffercorp.com